

# inmc news

issue 1

## Editorial

This is the first real INMC Newsletter, at last. I'm sorry it took so long to get the ball rolling. This issue is mostly in the form of "messages from our sponsor" but we hope this will change and that you, the members, will contribute the majority of the contents in future. We would like to hear from you if you would like to

- contribute a brief write up of an interesting application
- place a small ad (free to INMC members)
- start a local computer club
- heap praise (or blame) on us
- submit interesting circuits (e.g. for interfacing things)
- submit useful programs
- do anything else

Most programs will still be distributed in the usual way, but the smaller ones of general interest will be published in the Newsletter.

Please also let me know if you have any comments about the Newsletter format. Is it what you want? If so, tell us - it makes us feel wanted. If not, tell us so we can change it - the INMC is for you, not us.

I would like your advice on one particular point. It has been suggested that we publish a list of INMC members to help you get in touch with each other locally. This seems a good idea, but the list might then be used by anyone who gets hold of it for mail shots. This could increase the number of unwanted advertising material you get through the post. What do you think?

Having started, we hope to continue to issue the Newsletter at approximately six weekly intervals. I hope you like it.

A.R. RUNDLE

## Bristol Seminar

We held our third seminar, attended by over 200 people, at the Dragonara Hotel in Bristol on October 14th. This time the lectures were biased towards software and the titles were:

- Is there a computer in the house? - Guy Kewney, Computing
- Microprocessors and Microprocessing - Vincent Tseng, ICL Dataskil
- Microprocessor Software - Jim Ayres, Harrow Technical College
- Assemblers, High Level languages and Operating Systems - Tony Rundle  
Nascom Microcomputers Ltd.
- Interfacing - Paul Lister, Sussex University

Reprints of the papers will shortly be available at a price of £1.50 each and are recommended reading for Nascom owners.

Tiny Basic, Zeap and a prototype 32K Nascom were on display together with a number of applications, programs including games and a text processing system developed by Dataskil. We would like to thank everyone who came for helping to make a thoroughly enjoyable day.

## Nasbus

First of all, an apology for the delay producing the extension RAM and buffer boards. We have heard it said that there are no problems, only opportunities. Well, we have been beset by opportunities - some technical, some manufacturing. However the design is complete, pre-production prototypes have been tested, and first deliveries will be made in December.

The buffer board generates the Nasbus. This is a 77 way bus with some unique features. In particular:

- it does not require termination
- it uses low cost, single sided connectors
- it uses a low cost single sided backplane (motherboard)
- it is designed to cater for 16 bit systems at some future date.

We are confident that the Nasbus will become a significant feature of the microcomputer scene because of the simplicity, its low cost, and ability to cope with the next generation of microprocessors. A full specification will be available with the buffer boards in December.

## Hardware

### Power Supplies

First of all, our apologies. A small batch of pcb's escaped with the ground and output of ICL incorrectly marked, and the +12V and -12V markings reversed. ICL should be marked as

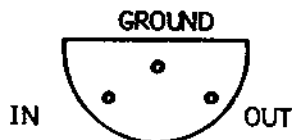

and the correct output order is

- 12V
- 5V
- +12V
- + 5V
- 0

The circuit diagram in some construction notes is also incorrect - C5, C6 and C7 are drawn reversed. The PCB is however correct and the markings on the board should be followed.

The stability and regulation of the power supplies can be improved by the addition of a 2.2UF Tantalum capacitor and a 0.1UF disc ceramic capacitor in parallel between -5V, -12V, +12V and ground, together with the addition of a 100R and 82R resistor as shown in the diagram below:

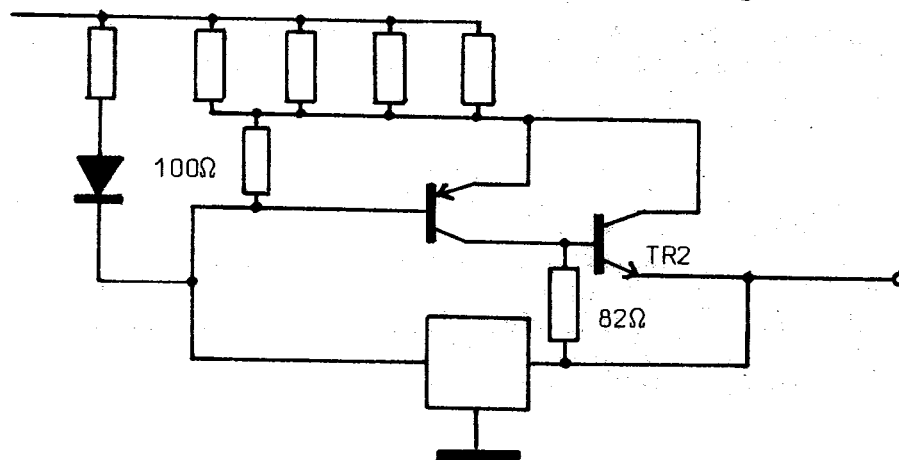

Contrary to some rumours we have heard, the small psu will drive a Nascom 1, a buffer board, and a memory board with up to 32K memory.

### Modulator

The Nascom 1 on board UHF modulator is capable of producing a good picture on a domestic T.V., although results in the field vary. If you have a poor picture and need a stronger signal, try reducing the value of R8. The winding of the coil can also be critical and seems to account for much of the variation between systems. Rather than spend too much time on this, we would recommend that you obtain a separate add-on, screened modulator from your local distributor. The cost is only £2.50 + VAT and well worth while. Fitting details are included.

### Screen-flash

During multiple video RAM accessing, some noise may appear on the screen. The circuit below has been published in ETI as a suggestion to overcome this.

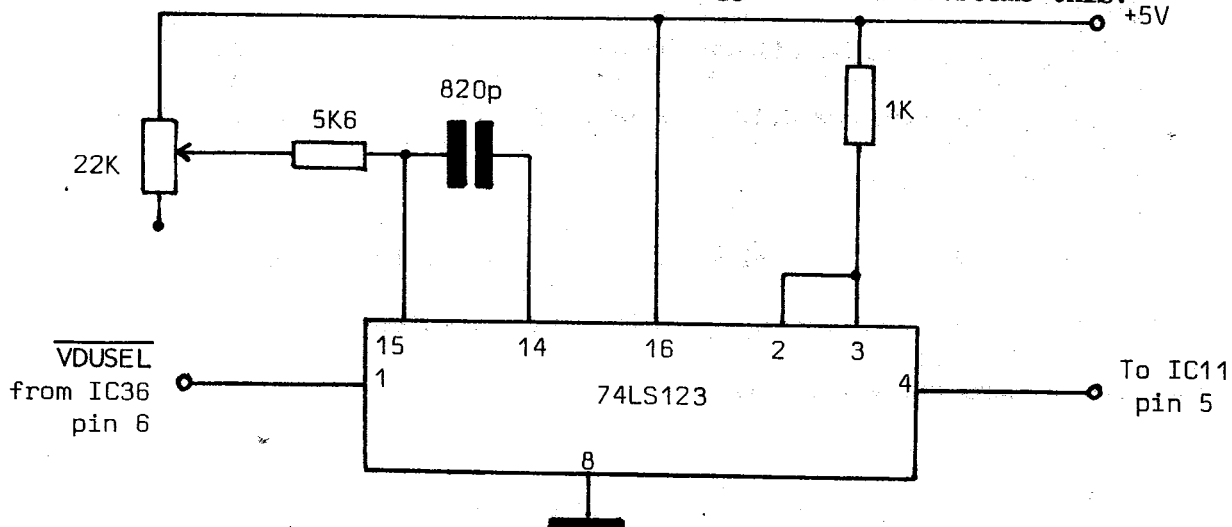

Pin 5 of IC11 should be bent out from the socket and the connections made with an insulated "soldercon" socket. Increase the potentiometer value until the flash just disappears.

We don't guarantee the results, but we've tried it and it seems to work!

### Cassette Loading

Due to an artwork error, pin 35 of the UART (parity inhibit) has been left floating. It should be tied to +5V, and this can be done by adding a small link on the solder side of the board between pins 34 and 35.

In practice we have found that the absence of a connection to this pin generally makes no difference, but it can occasionally cause intermittent cassette loading or incompatibility between systems. In certain circumstances it may be possible to increase the data transfer rate of the cassette load and dump. This can be done by increasing the frequency to pins 17 and 40 of the UART (IC29). The standard frequency at this point is 3.9 KHz, which is taken from IC2 pin 11. The transfer rate may be doubled by taking the UART clock from IC2 pin 12 (7.8 KHz) or quadrupled by taking the UART clock from IC2 pin 13 (15.625).

With each increase of speed, however, the record replay levels and the quality of the tape and recorder used, and variations between records become much more critical. Using a £40 portable cassette recorder and good quality tapes we have been achieving a 100% load rate at 4 times the standard speed.

If fitting this modification the option of selecting between the normal and fast speeds should be available. This could be done by feeding the higher frequency into Pin 1 on the Nascom (marked EXT SERIAL CLOCK) and then selecting between speeds by means of a switch at link 4.

It is recommended that cassette interchange between users should always be done with cassettes recorded at the standard speed. The higher transfer rate should only be used for loading and dumping the users own programs.

### Missing Characters

We have found that the tolerance of some manufacturers components can lead to problems with the timing of IC18 (74LS123). The problem manifests itself when a character with bit 6 set (e.g. any capital letter) is followed by a character with bit 6 clear (e.g. any number). If these are displayed on the screen, the first character will disappear!

The problem can usually be alleviated by (i) interchanging I.C.s 7 & 18 (ii) cutting off either leg 5 or 12 of I.C.18 and then putting a link across the solder side of the board between pins 5 & 12. (iii) changing the device for that of another manufacturer.

### Teletype Interfacing

We have had a number of enquiries about interfacing teletypes and other terminals to the Nascom 1. Both 20 mA loop and V24/RS232 serial interfaces are brought to Sk2. We suggest you make up a cable bringing these signals to a Cannon D type socket with the following pin allocations so that it is easy to change terminals or swap between systems.

<u>Signal Name</u>	<u>SK2 Name and Pin No.</u>	<u>Cannon Pin No.</u>
Chassis Ground	-	1
Data in V24	RS232 in (2)	2
Data out V24	RS232 out (14)	3 -
Request to send (RTS)	Generated by terminal	4
Clear to send (CTS)	-	5
Data set Ready (DSR)	-	6 -
Ov (Ground)	RS232 Com (8)	7
Carrier Detect	-	8
20mA input -ve	KBD - (4)	10
20mA output +ve	PTR + (12)	16
20mA output - ve	PTR - (11)	17
Reader step -ve	-	18
Reader step +ve	-	19
Data Terminal Ready (DTR)	Generated by terminal	20
20mA Input +ve	KBD + (5)	24

We have included a number of signals which are not generated by the Nascom-1 for your information and to aid standardisation. You can interface a relay to the PIO to provide reader step if required.

Because the Nascom keyboard users non-standard values for newline (IFH), you will need to patch \$KBD (0C4DH) and \$CRT (0C4AH) to generate carriage returns and line feed (0DH and 0AH) in place of newline on output, and replace them with newline on input. Don't forget that you may also need to ignore parity on input and generate it on output, depending on the terminal you are using.

You may like to take special action on receipt of a backspace (Nascom 1DH to ASCII 08H) or formfeed (Nascom 1EH to ASCII 0CH). (See also the software listing for a printer driver).

## Software

### Cassette Loading

As most of you probably know by now, the original version of Nasbug had an error which resulted in a high error rate when loading cassette tapes. A patch to correct this was sent to all INMC members sometime ago. However, a number of people appear not to have received this so we are re-publishing it as part of this newsletter (see below).

Nasbug version T2 has been modified to incorporate this patch and all kits sent out since early July already have this modification included. If you have an old version of Nasbug, you can send it back to us, enclosing £1.00 and we will reprogram it for you to bring it up to the T2 standard.

PROGRAM: TAPE LOAD  
 ROUTINE: IMPROVE ERROR RATE.

IN	P.C.	MACHINE CODE			LABEL	MN	Op. 1	Op. 2	COMMENTS
1	0C	50	E5		CHINX	PUSH	HL		SAVE HL
2		51	21	00 0C		LD	HL	#0C00	POINT HL AT PORT 0.
3		54	CB	66		BIT	4	(HL)	TEST MOTOR BIT
4		56	E1			POP	HL		RECOVER HL
5		57	CA	69 00		JP	Z	#0069	NO MOTOR, GO TO KBD ROUTINE
6		5A	DB	02	INLOOP	IN	A	#02	GET VART STATUS
7		5C	17			RL	A		ROTATE BIT TO CARRY.
8		5D	30	FB		JR	NC	#FB	IF NO DATA, JUMP TO INLOOP
9		5F	DB	01		IN	A	#01	GET VART DATA
10		61	C9			RET			RETURN TO LOAD ROUTINE
11		62	C3	50 0C		JP	UNCOND	#0C50	PLUG FOR \$KBD

- 1) Load the routine using the 'M' Command.
- 2) Execute a copy: COC62 OC4D 03 'NL'
- 3) After the copy do not use the 'Reset' until the tape load has been completed. If the 'Reset' is used the copy must be repeated.
- 4) Load as normal by 'L' 'NL'.

Note: This program can be located anywhere in user RAM by suitable modification of line 11 and the copy (Instruction 2)

Explanation

Following a 'Reset' the monitor program loads the scratchpad RAM locations OC4E & F with the address 0069. When the 'L' command is executed the monitor obtains the address of the routine to be used from OC4E & F (normally 0069) and executes this routine. By use of the copy command to modify the address held in OC4E & F, the monitor calls the modified load routine written in user RAM. Consequently, use of the reset must be avoided immediately following the copy as this would cause 0069 to be placed back in the scratchpad, and the normal load routine would be executed.

This routine is suggested for systems where a poor rate of loading has been experienced, our demonstration system has achieved a 100% success rate following the use of this routine.

## ZEAP

Zeap is an excellent in-store assembler, produced by Paul Chapman and Geoffrey Roughton. Its main features are

- users only 2.75K memory (how they did that we don't know)
- uses standard Z80 mnemonics
- includes powerful screen editor
- program storage on cassette tape

Cassettes are available at £32.00. A brochure is enclosed with this newsletter.

## Tiny Basic

Nascom Tiny Basic is a version of Palo Alto Tiny Basic with some useful extensions. In particular it allows storage and retrieval of programs from cassette and includes a machine code subroutine call facility which allows you to extend it to do things like address vdu RAM directly, control PIO's etc.

This makes it ideal for games and control applications requiring no floating point. It is being distributed on two EPROMs and will be released in December with the memory boards. We've been using Tiny Basic on a prototype extended Nascom for sometime now and it is amazing how quickly you can get quite complicated programs working.

## Driving Printers

A Centronics printer can easily be interfaced to the PIO by making up a cable as follows:

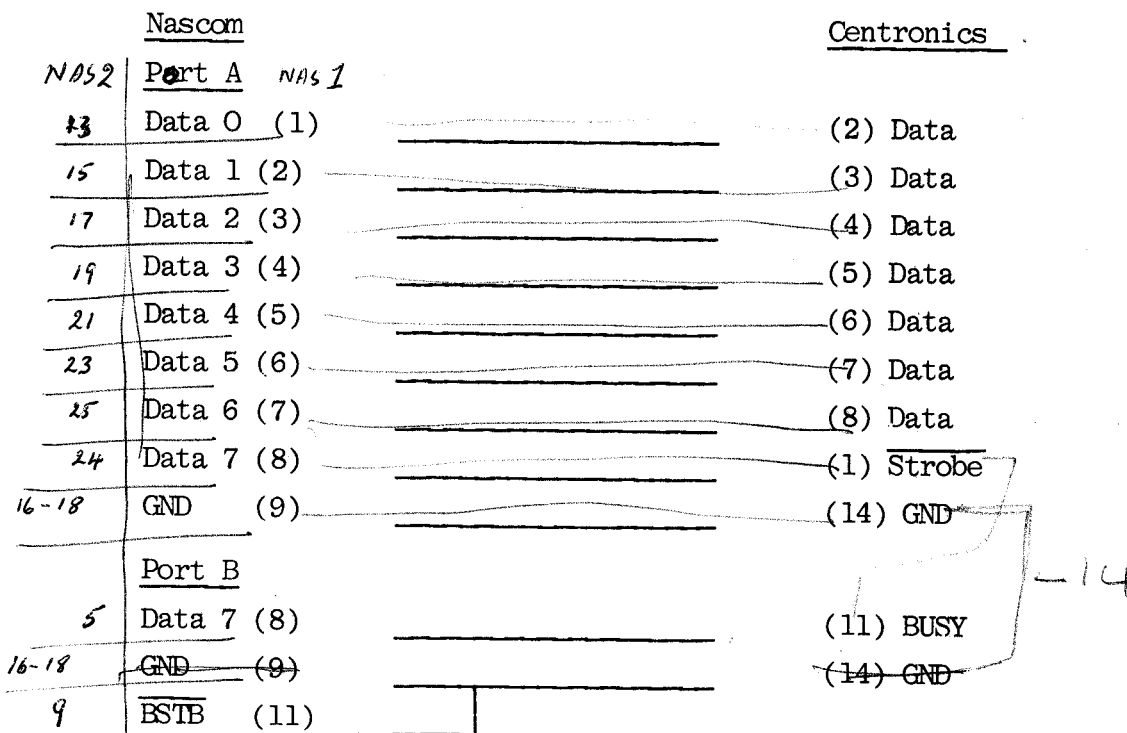

A software routine to drive the printer is listed below. We are reproducing it here since it may also be of interest to those with other types of printers or driving other devices via the P.I.O.

```

0001 ;
0002 ;
0003 ;
0004 ;
0005 ;
(0004) 0006 ADATA: EQU 4
(0005) 0007 BDATA: EQU 5
(0006) 0008 ACTRL: EQU 6
(0007) 0009 BCTRL: EQU 7
0010 ;
0000' 0011 ORG 0C50H
0012 ;
0013 ;
0014 ;
0015 ;
0016 ;
0C50 F5 0017 PRINT; PUSH AF ;SAVE A&F
0C51 FE1D 0018 CP IDH ;IS IT NASCOM BS?
0C53 2002 0019 JR NZ,P10 ;NO, SKIP
0C55 3E08 0020 LD A,08H ;YES, USE ASCII BS
0C57 FE1E 0021 P10: CP 1EH ;IS IT NASCOM FF?
0C59 2002 0022 JR NZ,P20 ;NO, SKIP
0C5B 3E0C 0023 LD A,0CH ;YES, USE ASCII FF
0C5D FE1F 0024 P20: CP 1FH ;IS IT NASCOM CR?
0C5F 2002 0025 JR NZ,P30 ;NO, SKIP
0C61 3E0D 0026 LD A,0DH ;THEN CR
0C63 CD680C 0027 P30: CALL PCHAR ;SEND THE CHARACTER
0C66 F1 0028 POP AF ;RESTORE A&F
0C67 C9 0029 RET
0030 ;
0031 ;
0032 ;
0033 ;
0C68 F5 0034 PCHAR: PUSH AF ;SAVE CHARACTER
0C69 3E0F 3ECF 0035 LD A,0FH CF ;PIO MODE 0 (OUTPUT)
0C6B D306 0036 OUT ACTRL,A ;SET PORT A
0C6D 3E4F 0037 LD A,4FH ;PIO MODE 1 (INPUT)
0C6F D307 3ECC 0038 OUT BCTRL,A ;SET PORT B
0C71 DB05 0039 PRDY: IN A,BDATA ;IN FROM PORT B
0C73 17 0040 RLA ;ROTATE BIT 7 INTO CY
0C74 38FB 0041 JR C,PRDY ;WAIT TIL 0
0C76 F1 0042 POP AF ;GET THE CHARACTER BACK
0C77 CBFF 0043 SET 7,A ;SET M.S.BIT
0C79 D304 0044 OUT ADATA,A ;SET IT
0C7B CBBF 0045 RES 7,A ;CLEAR M.S.BIT
0C7D D304 0046 OUT ADATA,A ;SEND IT
0C7F CBFF 0047 SET 7,A ;SET IT AGAIN
0C81 D304 0048 OUT ADATA,A ;SEND IT
0C83 C9 0049 RET ;RETURN TO CALLER
0050 ;
0051 ;
0052 ;
0053 ;
0C84 CD3B01 0054 ECHO: CALL 013BH ;NORMAL CRT ROUTINE
0C87 C3500C 0055 JP PRINT ;PRINT AND RETURN
0056 ;
0057 ;
NEW VALUE FOR THE $CRT REFLECTION

```



```

0058 ;
0C8A C3840C 0059 JP ECHO
0060 ;
0061 ; EXECUTING THIS PROGRAM WILL CHANGE THE
0062 ; PRINTER FORMAT. PATCH THE CORRECT CODE
0063 ; INTO LOCATION 0CDEH TO SELECT THE DESIRE
0064 ; FORMAT:-
0065 ; 0FH - START UNDERLINING
0066 ; 0EH - STOP UNDERLINING
0067 ; LDH - SET PITCH TO 20 CHARS/IN
0068 ; LEH - SET PITCH TO 10 CHARS/IN
0069 ; LFH - SET PITCH TO 5 CHARS/IN
0070 ;
0071 FORM: LD A,LEH ;CONTROL CODE TO A
0072 CALL PCHAR ;SEND IT
0073 JP 0286H ;BACK TO THE MONITOR
0074 END

```

ERRORS 0

END OF ASSEMBLY

A.

Kit Repairs

We have now instituted a flat £25.00 fee for kit repairs, regardless of how long it takes us to fix them. We have increased our staff and have reduced our backlog to be able to give you a more responsive service. Many of our distributors offer a similar service. Of course, if you find a faulty component you can still return it to us within 90 days for replacement free of charge. Please enclose proof of purchase (e.g. a receipt) otherwise we will end up supplying free components to the whole world!

Incidentally, we have had one or two cases of faulty keyboards (not bad considering the thousands we've shipped). If you have a problem, please don't modify it, return it to us for replacement or repair. If you attempt to fix it you may invalidate the manufacturers guarantee.

Situations Vacant

Nascom Microcomputers Ltd. are expanding and need experienced professionals to fill the following posts:

Production Engineer

To be responsible for taking designs from the prototype stage through to production. This will include developing test equipment and test schedules, liaising with subcontractors etc.

Development Engineer

The Development Engineer will join a team developing new products for Nascom Microcomputers. Many new and exciting products are planned and this position will be particularly challenging.

Test Engineer

To test and repair the range of Nascom boards. The work is interesting and varied and offers the opportunity to keep up to date with current microprocessor technology.

Programmer

To extend and maintain interpreters, compilers and operating systems, and to write test programs.

All posts offer the chance to play a key role in consolidating Nascom Microcomputers position as Europes most successful microcomputer company. Competetive salaries will be offered.

If you would like to be considered for any of the above posts, please send a career resume to:

Mr. W. Bulman  
Nascom Microcomputers Ltd.,  
92 Broad Street,  
Chesham,  
Bucks.